

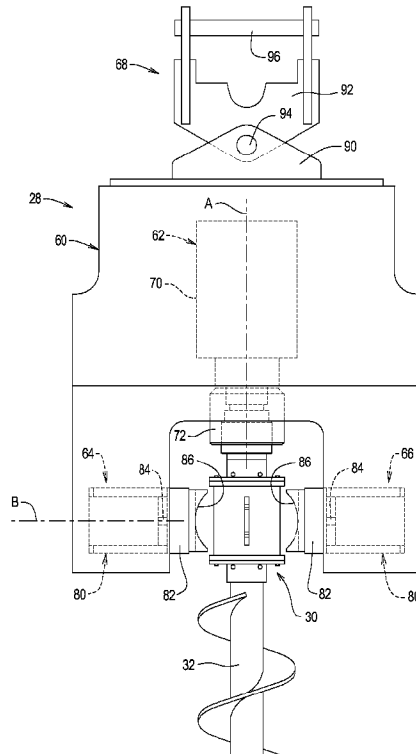

(86) Date de dépôt PCT/PCT Filing Date: 2014/07/02  
 (87) Date publication PCT/PCT Publication Date: 2015/01/08  
 (45) Date de délivrance/Issue Date: 2020/01/07  
 (85) Entrée phase nationale/National Entry: 2016/01/05  
 (86) N° demande PCT/PCT Application No.: US 2014/045280  
 (87) N° publication PCT/PCT Publication No.: 2015/003074  
 (30) Priorités/Priorities: 2013/07/05 (US61/843,294);  
 2014/07/01 (US14/321,632)

(51) Cl.Int./Int.Cl. *E02D 7/22* (2006.01)  
 (72) Inventeurs/Inventors:  
 SUVER, PAUL, US;  
 MILLER, DAN, US  
 (73) Propriétaire/Owner:  
 AMERICAN PILEDRIVING EQUIPMENT, INC., US  
 (74) Agent: FINLAYSON & SINGLEHURST

(54) Titre : SYSTEMES ET PROCEDES DE RACCORDEMENT D'ACCESSOIRE DESTINES A ETRE UTILISES AVEC  
 DES SYSTEMES D'ENTRAINEMENT DE PIEU HELICOIDAL  
 (54) Title: ACCESSORY CONNECTION SYSTEMS AND METHODS FOR USE WITH HELICAL PILE DRIVING  
 SYSTEMS



(57) **Abrégé/Abstract:**

An accessory mounting system a swivel assembly has a swivel member defining first and second swivel member connector portions, a swivel housing, and first and second bearings operatively arranged between the swivel member and the swivel housing.

(57) **Abrégé(suite)/Abstract(continued):**

The accessory mounting system operatively connects a helical pile driving system having a rotational drive system and at least one clamp system to an accessory. The first swivel member connector portion is adapted to operatively connect the swivel member to the drive system. The second swivel member connector portion is adapted to operatively connect the swivel member to the accessory. The swivel housing is adapted to engage the at least one clamp system such that the clamp system may be operated to fix a position of the swivel housing relative to the drive system. The first and second bearings are configured to allow rotation of the swivel member relative to the swivel housing.

(12) INTERNATIONAL APPLICATION PUBLISHED UNDER THE PATENT COOPERATION TREATY (PCT)

(19) World Intellectual Property  
Organization  
International Bureau(10) International Publication Number  
**WO 2015/003074 A1**(43) International Publication Date  
8 January 2015 (08.01.2015)(51) International Patent Classification:  
*E02D 7/22* (2006.01)(21) International Application Number:  
PCT/US2014/045280(22) International Filing Date:  
2 July 2014 (02.07.2014)

(25) Filing Language: English

(26) Publication Language: English

(30) Priority Data:  
61/843,294 5 July 2013 (05.07.2013) US  
14/321,632 1 July 2014 (01.07.2014) US(71) Applicant: **AMERICAN PILEDIVING EQUIP-  
MENT, INC.** [US/US]; 7032 South 196th Street, Kent,  
WA 98032 (US).

(72) Inventors; and

(71) Applicants : **SUVER, Paul** [US/US]; 7032 South 196th  
Street, Kent, WA 98032 (US). **MILLER, Dan** [US/US];  
7032 South 196th Street, Kent, WA 98032 (US).(74) Agent: **SCHACHT, Michael, R.**; Schacht Law Office,  
Inc., 2801 Meridian Street, Suite 202, Bellingham, WA  
98225 (US).(81) Designated States (*unless otherwise indicated, for every  
kind of national protection available*): AE, AG, AL, AM,  
AO, AT, AU, AZ, BA, BB, BG, BH, BN, BR, BW, BY,  
BZ, CA, CH, CL, CN, CO, CR, CU, CZ, DE, DK, DM,  
DO, DZ, EC, EE, EG, ES, FI, GB, GD, GE, GH, GM, GT,  
HN, HR, HU, ID, IL, IN, IR, IS, JP, KE, KG, KN, KP, KR,  
KZ, LA, LC, LK, LR, LS, LT, LU, LY, MA, MD, ME,  
MG, MK, MN, MW, MX, MY, MZ, NA, NG, NI, NO, NZ,  
OM, PA, PE, PG, PH, PL, PT, QA, RO, RS, RU, RW, SA,  
SC, SD, SE, SG, SK, SL, SM, ST, SV, SY, TH, TJ, TM,  
TN, TR, TT, TZ, UA, UG, US, UZ, VC, VN, ZA, ZM,  
ZW.

[Continued on next page]

(54) Title: ACCESSORY CONNECTION SYSTEMS AND METHODS FOR USE WITH HELICAL PILE DRIVING SYSTEMS

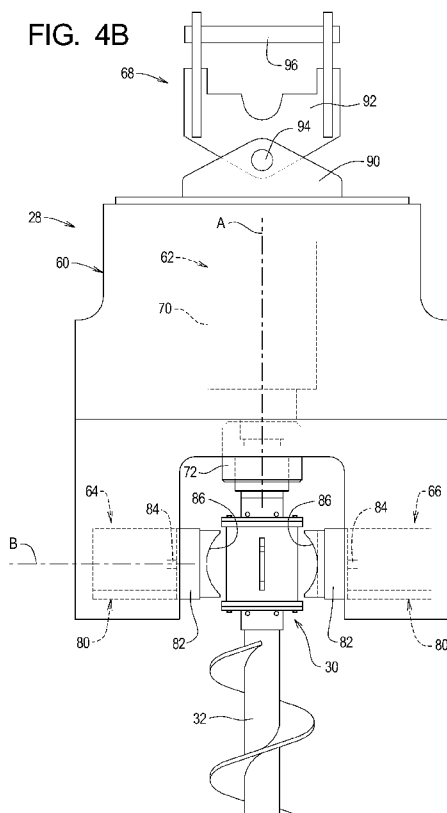

(57) Abstract: An accessory mounting system a swivel assembly has a swivel member defining first and second swivel member connector portions, a swivel housing, and first and second bearings operatively arranged between the swivel member and the swivel housing. The accessory mounting system operatively connects a helical pile driving system having a rotational drive system and at least one clamp system to an accessory. The first swivel member connector portion is adapted to operatively connect the swivel member to the drive system. The second swivel member connector portion is adapted to operatively connect the swivel member to the accessory. The swivel housing is adapted to engage the at least one clamp system such that the clamp system may be operated to fix a position of the swivel housing relative to the drive system. The first and second bearings are configured to allow rotation of the swivel member relative to the swivel housing.

WO 2015/003074 A1

**WO 2015/003074 A1** 

- (84) Designated States** (*unless otherwise indicated, for every kind of regional protection available*): ARIPO (BW, GH, GM, KE, LR, LS, MW, MZ, NA, RW, SD, SL, SZ, TZ, UG, ZM, ZW), Eurasian (AM, AZ, BY, KG, KZ, RU, TJ, TM), European (AL, AT, BE, BG, CH, CY, CZ, DE, DK, EE, ES, FI, FR, GB, GR, HR, HU, IE, IS, IT, LT, LU, LV, MC, MK, MT, NL, NO, PL, PT, RO, RS, SE, SI, SK, SM, TR), OAPI (BF, BJ, CF, CG, CI, CM, GA, GN, GQ, GW, KM, ML, MR, NE, SN, TD, TG).
- Published:**
- *with international search report (Art. 21(3))*
  - *before the expiration of the time limit for amending the claims and to be republished in the event of receipt of amendments (Rule 48.2(h))*

**ACCESSORY CONNECTION SYSTEMS AND METHODS FOR USE WITH  
HELICAL PILE DRIVING SYSTEMS**

TECHNICAL FIELD

**[0001]** The present invention relates to systems and methods for forming holes in the earth and, more particularly, to systems and methods for forming holes in the earth using a helical pile installation device.

BACKGROUND

**[0002]** Helical piles are elongate members having a helical blade at the lower end. The helical pile is supported upright with the helical blade adjacent to a desired insertion point and rotated such that the helical blade draws the helical pile into the earth at the desired insertion point.

**[0003]** In some situations, the conditions of the earth may prevent easy insertion of the helical pile using a standard helical pile driving system. In this case, another type of earthwork equipment must be procured and used to form a pilot hole or the like. Once the pilot hole has been formed, the standard helical pile driving system may be used to drive the helical pile in a conventional manner. The procurement of another type of earthwork equipment can result in delays on the jobsite.

**[0004]** The need thus exists for improved systems and methods for driving helical piles using standard helical pile driving systems.

## SUMMARY

**[0005]** The present invention may be embodied as an accessory mounting system for operatively connecting a helical pile driving system comprising a rotational drive system and at least one clamp system to an accessory. The accessory mounting system comprises a swivel assembly comprising a swivel member defining first and second swivel member connector portions, a swivel housing, and first and second bearings operatively arranged between the swivel member and the swivel housing. The first swivel member connector portion is adapted to operatively connect the swivel member to the drive system. The second swivel member connector portion is adapted to operatively connect the swivel member to the accessory. The swivel housing is adapted to engage the at least one clamp system such that the clamp system may be operated to fix a position of the swivel housing relative to the drive system. The first and second bearings are configured to allow rotation of the swivel member relative to the swivel housing.

**[0006]** The present invention may also be embodied as a method of operatively connecting a helical pile driving system comprising a rotational drive system and at least one clamp system to an accessory. A method of the present invention may comprise the following steps. A swivel member defining first and second swivel member connector portions is provided. A swivel housing is provided. First and second bearings are provided. The first and second bearings are arranged between the swivel member and swivel housing to allow rotation of the swivel member relative to the swivel housing. The swivel member is operatively connected to the drive system using the first swivel member connector portion. The swivel member is operatively connected to the accessory using the second swivel member connector portion. The clamp system is operated to fix a position of the swivel housing relative to the drive system by engaging the swivel housing with the at least one clamp system.

**[0007]** The present invention may also be embodied as a system for driving a helical pile comprising a rotational drive system adapted to drive the helical pile, at least one clamp system, at least one accessory, and a swivel assembly. The swivel assembly comprises a swivel member

defining first and second swivel member connector portions, a swivel housing, and first and second bearings operatively arranged between the swivel member and the swivel housing. The first swivel member connector portion is adapted to operatively connect the swivel member to the drive system. The second swivel member connector portion is adapted to operatively connect the swivel member to the at least one accessory. The swivel housing is adapted to engage the at least one clamp system such that the clamp system may be operated to fix a position of the swivel housing relative to the drive system. The first and second bearings are configured to allow rotation of the swivel member relative to the swivel housing.

**[0008]** In a broad aspect, the present invention pertains to a mounting system for operatively connecting a helical pile driving system, comprising a rotational drive system defining a drive connector and at least one clamp system to a helical pile defining a pile connector, and to an accessory defining an accessor connector. The accessory mounting system comprises a swivel assembly defining a swivel assembly first connector and a swivel assembly second connector. The swivel assembly comprises a swivel housing and a swivel member middle portion, where the swivel member is arranged at least partly within the swivel housing such that the middle portion and the swivel housing define a swivel chamber. The swivel assembly first connector extends from an upper end of the middle portion, the swivel assembly second connector extends from a lower end of the middle portion, and the swivel assembly second connector extends from a lower end of the middle portion. First and second bearings are operatively arranged between the swivel member and swivel housing to support the swivel member for axial rotation relative to the swivel housing. The mounting system operates in a first mode in which the swivel assembly first connector engages the drive connector to connect the swivel member to the rotational drive system. The swivel assembly second connector engages the accessory connector to connect the swivel member to the accessory. The at least one clamp system engages the swivel housing such that the clamp system secures the swivel housing to the rotational drive system, and operation of the rotational drive system causes rotation of the accessory. A second mode in which the pile connector engages the drive connector connects the helical pile to the rotational drive system, and operation of the rotational drive system causes rotation of the helical pile.

**[0009]** In a further aspect, the present invention embodies a method of operatively connecting a helical pile driving system comprising a rotational drive system and at least one clamp system to a helical pile and to an accessory. The method comprises providing a swivel member defining first and second member connector portions, a swivel housing, and first and second bearings. A swivel assembly is formed by arranging the first and second bearings between the swivel member and the swivel housing to allow rotation of the swivel member relative to the swivel housing. The method provides for operating in a first mode, by operatively connecting the swivel member to the drive system using the first swivel member connector portion, operatively connecting the swivel member to the accessory using the second swivel member connector portion, operating the clamp system to secure the swivel housing to the drive system by engaging the swivel housing with the at least one clamp system, and operating the rotational drive system to cause rotation of the accessory. The method provides operation in a second mode, by operatively connecting the helical pile to the rotational drive system, and operating the rotational drive system to cause rotation of the helical pile.

**[0009A]** Yet further, the present invention provides a drive system for driving a helical pile, comprising a rotational drive system adapted to drive the helical pile, at least one clamp system, and at least one accessory. A swivel assembly comprises a swivel member defining first and second swivel member connector portions, a swivel housing, first and second bearings operatively arranged between the swivel member and the swivel housing to allow rotation of the swivel member relative to the swivel housing, and at least one adapter member defining first and second adapter member connector portions. The first swivel member connector portion is adapted to engage the first adapter member connector portion, to operatively connect the swivel member to the adapter member. The second adapter member connector portion is adapted to engage the rotational drive system, to operatively connect the at least one adapter member to the rotational drive system. The second swivel member connector portion is adapted to engage the at least one accessory, to operatively connect the swivel member to the at least one accessory, the first adapter member connector portion engaging the first swivel member connector portion to detachably attach the at least one adapter member to the swivel



member. The second adapter member connector portion engages the rotational drive system, to detachably attach the swivel member to the rotational drive system. The second swivel member connector portion engages the at least one accessory, to attach the swivel member to the at least one accessory. The at least one clamp system engages the swivel housing such that the clamp system secures the swivel housing relative to the rotational drive system, and operation of the rotational drive system causes rotation of the accessory.

#### BRIEF DESCRIPTION OF THE DRAWINGS

**[0010]** Figure 1A is a side elevation view of an example drive system for helical piles driving an example helical pile;

**[0011]** Figure 1B is a side elevation view of the example helical pile being driven in Figure 1;

**[0012]** Figure 2A is a side elevation view of the example helical pile driving

system of Figure 1 using an accessory mounting system of the present invention to use an accessory;

**[0013]** Figure 2B is side elevation view of the example accessory being used in Figure 2;

**[0014]** Figure 3A is a front elevation view of a rotational drive system connected to the helical pile, with the rotational drive system being depicted in a clamped configuration;

**[0015]** Figure 3B is a front elevation view of a rotational drive system connected to the helical pile, with the rotational drive system being depicted in an unclamped configuration;

**[0016]** Figure 4A is a front elevation view of an example accessory connection system connected between the rotational drive system and a drive accessory, with the rotational drive system being depicted in the clamped configuration;

**[0017]** Figure 4B is a front elevation view of the example accessory connection system connected between the rotational drive system and the drive accessory, with the rotational drive system being depicted in the unclamped configuration;

**[0018]** Figure 5 is an elevation view illustrating the example accessory connection system;

**[0019]** Figure 6 is a section, elevation view the example accessory connection system;

- [0020]** Figure 7 is a section, elevation view of a swivel assembly of the example accessory connection system;
- [0021]** Figure 8 is an elevation view of a first example adapter assembly of the example accessory connection system;
- [0022]** Figure 9 is a section, elevation view of the first example adapter assembly;
- [0023]** Figure 10 is an elevation view of a second example adapter assembly of the example accessory connection system;
- [0024]** Figure 11 is a section, elevation view of the second example adapter assembly;
- [0025]** Figure 12 is an elevation view of a third example adapter assembly of the example accessory connection system; and
- [0026]** Figure 13 is a section, elevation view of the third example adapter assembly.
- [0027]** Figure 14 is a side elevation view of a second accessory mounting system of the present invention;
- [0028]** Figure 15 is section view taken along lines 15-15 in Figure 14; and
- [0029]** Figure 16 is an enlarged view of a portion of Figure 15.

## DETAILED DESCRIPTION

**[0030]** Figures 1A, 3A, and 3B depict an example helical pile driving system 20 for driving helical piles 22 into the earth 24. The helical pile driving system 20 comprises a support system 26 and a rotational drive system 28 connected to the support system 26. The example support system 26 is or may be formed by a conventional excavator. The example rotational drive system 28 is or may be the HD70 Helical Pile Driver sold by American Piledriving Equipment, Inc., but the principles of the present invention may be applied to other rotational drive systems. The support system 26 and rotational drive system 28 are thus both known in the art and will not be described in detail herein beyond that extent necessary for a complete understanding of the present invention.

**[0031]** Figures 4A, 4B, 5, and 6 illustrate an example accessory mounting system 30 and an accessory 32 that may be used with the helical pile driving system 20 to facilitate driving of the helical piles 22 under certain conditions. The accessory 32 may be a device such as an auger, a drill, a downhole hammer, or the like. The example accessory mounting system 30 allows the accessory 32 to be quickly and easily connected to and disconnected from the rotational drive system 28 as will be described in further detail below.

**[0032]** As shown in Figure 1B, the example helical pile 22 comprises a shaft 40, a blade 42, and a drive projection 44. The blade 42 and drive projection 44 are rigidly connected to the shaft 40 such that a rotational force applied to the drive projection 44 is transmitted through the shaft 40 to the blade 42.

**[0033]** In use as shown in Figures 1A and 3A, the rotational drive system 28 is detachably attached to the helical pile 22. The support system 26 then supports the rotational drive system 28 such that the helical pile 22 is held in contact with

the earth 24. The rotational drive system 28 is then operated such that a rotational force causes axial rotation of the shaft 40 and thus the blade 42. With the blade 42 in contact with the earth 24, the blade 42 will engage the earth such that the shaft 40 is displaced along its axis into the earth 24. However, under some conditions, it may be difficult or impossible for the blade 42 alone to penetrate the earth 24 and thereby drive the helical pile 22 into the earth 24. In these conditions, it may be desirable to form a pilot hole for the helical pile 22 using the accessory 32.

**[0034]** As depicted in Figure 2B, the example accessory 32 is an auger and comprises an auger shaft 50, an auger blade 52, and an auger male connector 54. The use of the example accessory 32 in the form of an auger to form a pilot hole will be described herein. However, the example accessory mounting system 30 may be configured to allow other types of accessories, such as drills and downhole hammers, and be used for purposes other than rotating a helical pile, including forming a pilot hole in the earth 24 for a helical pile. Accordingly, whenever formation of a hole in the earth is required, the example accessory mounting system 30 allows such holes to be driven with a helical pile driving device such as the example rotational drive system 28, even outside of the context of driving a helical pile.

**[0035]** Turning now to Figures 3A, 3B, 4A, and 4B, it can be seen that the example rotational drive system 28 comprises a housing 60, a drive system 62 defining a drive axis A, and first and second clamp systems 64 and 66 defining a clamp axis B. A hitch assembly 68 is formed on the housing 60. The example drive 62 comprises a drive motor 70 and a drive socket 72. The first and second clamp systems 64 and 66 each comprise an actuator 80, a piston member 82, and an actuator shaft 84. A gripping surface 86 is formed on the piston member 82. The hitch assembly 68 comprises a hitch plate 90 rigidly connected to the

housing 60, a hitch member 92, and first and second hitch pins 94 and 96. The hitch plate 90 is rigidly connected to the housing 60, and the first hitch pin 94 rotatably attaches the hitch member 92 to the hitch plate 90. The second hitch pin 96 rotatably attaches the hitch member 92 to the support system 26.

**[0036]** During use of the rotational drive system 28, operation of the drive motor 70 causes axial rotation of the drive socket 72 relative to the housing 60. Operation of the actuators 80 causes the piston members 82 to move relative to the housing 60 towards and away from the drive axis A along the piston axis B.

**[0037]** When used to drive the helical piles 22, the rotational drive system 28 is arranged such that the drive projection 44 on a selected pile 22 is adjacent to the drive socket 72. The clamp systems 64 and 66 are then operated to grip the pile 22. The support system 26 may then be operated to lift at least a first or upper end of the pile 22 and move the pile 22 such that a second or lower end of the pile 22 is held at a desired location relative to the earth 24. The piston members 82 axially rotate about the clamp axis B to allow the pile 22 to rotate into a desired angle relative to horizontal as the pile 22 is lifted. At this point, the drive axis A is substantially aligned with the longitudinal axis of the pile 22. The clamp systems 64 and 66 are then operated in the unclamped configurations to allow the drive projection 44 to enter the drive socket 72. The example drive projection 44 and the example drive socket 72 have conforming octagonal shapes such that rotational movement of the drive socket 72 is transferred to the drive projection 44. At this point, the drive motor 70 is operated such that the pile blade 42 engages the earth 24 to drive the pile 22 into the earth 24.

**[0038]** Turning now to Figures 4A, 4B, and 5-9, the example accessory mounting system 30 will be described. The example accessory mounting system 30 comprises an adapter assembly 120 as shown in Figures 4A, 4B, 5, 6, 8 and

9 and a swivel assembly 122 as shown in Figures 5, 6, and 7. As perhaps best shown in Figure 6, a first connection system 124 connects the adapter assembly 120 to the swivel assembly 122, and a second connection system 126 connects the swivel assembly 122 to the accessory 32. The first and second connection systems 124 and 126 are or may be industry standard 120 mm Jeffrey couplers or connectors.

**[0039]** In particular, the adapter assembly 120 comprises a drive portion 130 and an adapter male connector 132. The swivel assembly 122 comprises a first female connector 140 and a second female connector 142. The first female connector 140 receives the adapter male connector 132, and adapter connector pins 150 join the adapter assembly 120 to the swivel assembly 122. The second female connector 142 receives the auger male connector 54, and accessory connector pins 152 join the accessory 32 to the swivel assembly 122.

**[0040]** As perhaps best shown in Figure 7, the swivel assembly 122 comprises a swivel member 160, a swivel housing assembly 162, and first and second bearings 164 and 166. The swivel member 160 comprises a middle portion 160a and first and second end portions 160b and 160c. Bearing surfaces 160d and 160e are formed at the junctures of the middle portion 160a and the first end portion 160b and of the middle portion 160a and the second end portion 160c, respectively. The swivel housing assembly 162 comprises a housing member 170, a first housing cap 172, and a second housing cap 174. Bolts 176 secure the first and second caps 172 and 174 to the housing member 170 to form the swivel housing assembly 162. A swivel tab 178 is rigidly connected to the swivel housing member 170 to facilitate handling of the accessory mounting system 30.

**[0041]** When the swivel assembly 122 is formed, the swivel member 160 is

arranged within the swivel housing assembly 162 such that the first bearing 164 is held between the first cap 172 and the first bearing surface 160d and the second bearing 166 is held between the second cap and the second bearing surface 160e. The bearings 164 and 166 thus allow axial rotation of the swivel member 160 relative to the swivel housing assembly 162.

**[0042]** In addition, the example swivel assembly 122 comprises first and second end seals 180 and 182 and first and second side seals 184 and 186. The first and second end seals 180 and 182 are arranged to form seals between the end caps 172 and 174 and the swivel member 160, respectively. The first and second side seals 184 and 186 are arranged to form seals between the first and second end caps 172 and 174 and the swivel member 160, respectively.

**[0043]** In the example swivel assembly 122, an annular swivel chamber 190 is formed within the swivel housing assembly 162 around the swivel member 160. The swivel chamber 190 may be filled with lubricant such as oil to lubricate the bearings 164 and 166. The swivel member 160 may further define an inner chamber 192 extending between the first and second female connectors 140 and 142. The inner chamber 192 reduces weight of the accessory mounting system 30 and allows fluid to flow through the accessory mounting system 30 as will be described in further detail below.

**[0044]** When required, the accessory mounting system 30 may be used to attach the accessory 32 to the rotational drive system 28 as shown in Figures 4A, 4B, 5, and 6. With the accessory 32 joined to the accessory mounting system 30 using the first connection system 124, the rotational drive system 28 is arranged such that the drive portion of the adapter assembly 120 is adjacent to the drive socket 72 of the drive system 62. The clamp systems 64 and 66 are then operated to engage the housing member 170 and thus grip the accessory



mounting system 30. The support system 26 may then be operated to lift at least a first or upper end of the accessory mounting system 30 and accessory 32 attached thereto and move the accessory mounting system 30 and accessory 32 such that a second or lower end of the accessory 32 is held at a desired location relative to the earth 24. The piston members 82 axially rotate about the clamp axis B to allow the accessory 32 to rotate into a desired angle relative to horizontal as the accessory 32 is lifted. At this point, the drive axis A is substantially aligned with the longitudinal axis of the accessory 32.

**[0045]** The clamp systems 64 and 66 are then operated in the unclamped configurations to allow the drive portion 130 to enter the drive socket 72. The example drive portion 130 and the example drive socket 72 have conforming octagonal shapes such that rotational movement of the drive socket 72 is transferred to the drive portion 130. At this point, the clamp systems 64 and 66 are operated to prevent relative movement of the accessory mounting system 30 relative to the housing 60 and stabilize the accessory 32 relative to the housing 60. The drive motor 70 may then be operated such that auger blade 52 of the example accessory 32 drills a pilot hole for a helical pile 22. As generally described above, other accessories may be rotated using the accessory mounting system 30 in a similar manner.

**[0046]** After one or more pilot holes are drilled, the accessory mounting system 30 and accessory 32 may be quickly and easily detached from the rotational drive system 28, and helical piles 22 may be lifted and driven with the assistance of the previously driven pilot hole or holes.

**[0047]** As mentioned above, the inner chamber 192 allows fluid to flow between the first and second female connectors. The American Piledriving Equipment HD70 rotational drive system allows the helical pile 22 to be filled with

grout as the pile 22 is being driven as described herein. Other fluids such as water, drilling fluids, and/or air may be pumped through the inner chamber 192 and the accessory 32 to facilitate operation of the accessory 32. In this case, a seal assembly 220 may be formed within the drive portion 130 of the adapter assembly 120 as shown in Figures 6 and 9. The example seal assembly 220 comprises a seal member 230, a seal ring 232, a retaining ring 234, a first gasket 236, and a second gasket 238. This seal assembly 220 cooperates with the drive socket 72 of the rotational drive system 28 to allow pressurized fluid to flow through the inner chamber 192.

**[0048]** Figures 6 and 9 further show that the example adapter assembly 120 is formed by a first member 240 and a second member 242. These example first and second members 240 and 242 are welded together, but any configuration that forms a rigid structure that is fluid tight and rigidly transfers rotational forces applied to the first member 240 to the second member 242 may be used.

**[0049]** As described above, the drive socket 72 has an octagonal shape to transfer rotational movement generated by the drive motor 72 to the drive projection 44 of the pile 22 in one configuration and to the drive portion 130 of the adapter assembly 120 in another configuration. However, the dimensions of the drive socket 72 will vary depending upon such factors as the specifications of helical piles being driven for a particular job.

**[0050]** Figures 8 and 9 depict an adapter assembly 120 configured to mate with the first example drive socket 72. Figures 10 and 11 depict a second adapter assembly 120a configured to mate with a second example drive socket that is the same shape as the first example drive socket 72 but is larger in cross-sectional area. Figures 12 and 13 depict a third example adapter assembly 120b configured to mate with a third example drive socket that is the same shape as

the first and example drive sockets but is larger in cross-sectional area than the second example drive socket. The use of multiple adapter assemblies 120, 120a, and 120b thus allow the accessory mounting system 30 to be easily and quickly modified or adapted to use accommodate drive sockets of different sizes.

**[0051]** Turning now to Figures 14-16, a second example accessory mounting system 320 will be described. The second example accessory mounting system 320 is used, in a manner similar to that of the first example accessory mounting system 30 described above, to connect the rotational drive system 28 to the helical pile 22. The second example accessory mounting system 32 is, however, optimized for use with higher capacity rotational drive systems and larger helical piles.

**[0052]** The second example accessory mounting system 320 comprises an adapter assembly 322 and a swivel assembly 324. A first connection system 326 formed on the adapter assembly 322 connects the accessory mounting system 320 to the drive system 28, and a second connection system 328 formed on the swivel assembly 324 connects the accessory mounting system 320 to the accessory 32. The second connection system 328 is or may be an industry standard Jeffrey coupler or connector or the like.

**[0053]** The example adapter assembly 322 comprises a drive portion 330 and an adapter female connector 332 defining a threaded portion 334. The example swivel assembly 324 comprises a swivel assembly male connector 340 and a swivel assembly female connector 342. The swivel assembly male connector 340 defines a threaded portion 344 that receives the threaded portion 334 of the adapter female connector 332, and adapter connector pins 350 secure the adapter assembly 322 to the swivel assembly 324. The second female connector 342 receives the auger male connector 54, and accessory connector

pins 352 join the accessory 32 to the swivel assembly 324.

**[0054]** The example swivel assembly 324 comprises a swivel member 360, a swivel housing 362, and first and second bearings 364 and 366. The swivel member 360 comprises a middle portion 360a and first and second end portions 360b and 360c. Bearing surfaces 360d and 360e are formed at the junctures of the middle portion 360a and the first end portion 360b and of the middle portion 360a and the second end portion 360c, respectively. The swivel housing 362 comprises a housing member 370. A swivel tab 372 (FIG. 14) is rigidly connected to the swivel housing member 370 to facilitate handling of the accessory mounting system 30.

**[0055]** When the swivel assembly 324 is formed, the swivel member 360 is arranged within the swivel housing 362 such that part of the first bearing system 364 is held between the first cap 374 and part of the first bearing surface 360d and the second bearing system 366 is held between the second cap 376 and the second bearing surface 360e. In particular, the threaded surfaces 334 and 344 engage each other to pull the swivel member 360 towards the adapter assembly 322 such that the swivel member 360 clamps the bearing systems 364 and 366 on either end of the swivel housing 362 as shown in Figure 15

**[0056]** In particular, as perhaps best shown in Figure 16, each of the example bearing systems 364 and 366 comprises a thrust bearing 380 arranged between first and second thrust washers 382 and 384. The example thrust bearing 380 is made of aluminum bronze, and the thrust washers 382 and 384 are made of stainless steel. The thrust washers 382 and 384 are pinned to the adapter assembly 322 and the swivel housing 362 by first and second pins 386 and 388, respectively. And as perhaps best shown in Figure 15, first and second radial bearings 390 and 392 isolate the swivel member 360 from the swivel housing

362 to address radial loads. First, second, and third spacers 394, 396, and 398 maintain the radial bearings 390 and 392 at desired locations along the longitudinal axis of the swivel member 360 during operation of the accessory mounting system 320. The bearing systems 364 and 366 thus allow axial rotation of the swivel member 360 relative to the swivel housing 362.

**[0057]** The second example accessory mounting system 320 further comprises first and second lip seals 420 and 422 and an end seal 424. The first and second lip seals 420 and 422 are arranged to form seals between the end caps 374 and 376 and the swivel member 360, respectively. The end seal 424 is arranged to form a seal between the adapter assembly 322 and the swivel member 360.

**[0058]** In the example swivel assembly 324, a plurality of lubrication ports 430 are formed in the swivel housing 362. The lubricating ports 430 allow the application of lubricant such as oil to lubricate the bearing systems 364 and 366. The swivel member 360 may further define a swivel chamber 440, while the adapter assembly 322 defines an adapter chamber 442. The swivel chamber 440 reduces weight of the accessory mounting system 30 and allows fluid to flow from the adapter chamber 442 and through the accessory mounting system 30 as generally described above.

**[0059]** When required, the second accessory mounting system 320 may be used to attach the accessory 32 to the rotational drive system 28 in the same general manner as the first example accessory mounting system 30 described above. The rotational drive system 28 may then be operated to rotate the accessory 32 using the second accessory mounting system 320 to, for example, drill a pilot hole for a helical pile 22. As generally described above, other accessories may be rotated using accessory mounting system 30 in a similar

manner. After one or more pilot holes are drilled, the second example accessory mounting system 320 and the accessory 32 may be quickly and easily detached from the rotational drive system 28, and helical piles 22 may be lifted and driven with the assistance of the previously driven pilot hole or holes.

**[0060]** As mentioned above, the swivel chamber 440 allows fluid to flow through the second example accessory mounting system 320. The American Piledriving Equipment HD70 rotational drive system allows the helical pile 22 to be filled with grout as the pile 22 is being driven as described herein. Other fluids, such as water, drilling fluids, and/or air, may be pumped through the swivel chamber 440 and through, into, or around the accessory 32 to facilitate operation of the accessory 32. In this case, a seal assembly 450 may be formed within the drive portion 330 of the adapter assembly 322 as shown in Figure 15. This seal assembly 450 cooperates with the drive socket 72 of the rotational drive system 28 to allow pressurized fluid to flow through the swivel chamber 440.

What is claimed is:

1. An accessory mounting system for operatively connecting a helical pile driving system comprising a rotational drive system and at least one clamp system to an accessory, the accessory mounting system comprising:

a swivel assembly comprising

a swivel member defining first and second swivel member connector portions,

a swivel housing, and

first and second bearings operatively arranged between the swivel member and the swivel housing; wherein

the first swivel member connector portion is adapted to operatively connect the swivel member to the drive system;

the second swivel member connector portion is adapted to operatively connect the swivel member to the accessory;

the swivel housing is adapted to engage the at least one clamp system such that the clamp system may be operated to fix a position of the swivel housing relative to the drive system; and

the first and second bearings are configured to allow rotation of the swivel member relative to the swivel housing.

2. An accessory mounting system as recited in claim 1, in which the swivel housing comprises:

a swivel housing member;

a first housing cap secured to the swivel housing member; and

a second housing cap secured to the swivel housing member.

3. An accessory mounting system as recited in claim 2, in which:  
the swivel housing member defines first and second bearing surfaces;

the first bearing is held against the first bearing surface by the first housing cap; and

the second bearing is held against the second bearing surface by the second housing cap.

4. An accessory mounting system as recited in claim 1, in which a swivel chamber is defined by the swivel housing and the swivel member.

5. An accessory mounting system as recited in claim 1, in which the swivel member defines an inner chamber extending between the first and second swivel member connectors to allow fluid flow through the swivel member.

6. An accessory mounting system as recited in claim 1, in which:  
a swivel chamber is defined by the swivel housing and the swivel member;  
and  
the swivel member defines an inner chamber extending between the first and second swivel member connectors to allow fluid flow through the swivel member.

7. An accessory mounting system as recited in claim 1, further comprising an adapter assembly configured to transmit rotational movement of the rotational drive system to the swivel member.

8. An accessory mounting system as recited in claim 7, in which the adapter assembly comprises:  
a drive portion adapted to engage the rotational drive system; and  
an adapter connector that engages the first swivel member connector portion.



9. An accessory mounting system as recited in claim 1, further comprising a plurality of adapter assemblies configured to transmit rotational movement of the rotational drive system to the swivel member.

10. An accessory mounting system as recited in claim 9, in which each adapter assembly comprises:

a drive portion adapted to engage the rotational drive system; and  
an adapter connector that engages the first swivel member connector portion; wherein  
the drive portions are different on each of the plurality of adapter assemblies.

11. A method of operatively connecting a helical pile driving system comprising a rotational drive system and at least one clamp system to an accessory, the method comprising the steps of:

providing a swivel member defining first and second swivel member connector portions;  
providing a swivel housing;  
providing first and second bearings;  
arranging the first and second bearings between the swivel member and the swivel housing to allow rotation of the swivel member relative to the swivel housing;  
operatively connecting the swivel member to the drive system using the first swivel member connector portion;  
operatively connecting the swivel member to the accessory using the second swivel member connector portion; and  
operating the clamp system to fix a position of the swivel housing relative to the drive system by engaging the swivel housing with the at least one clamp system.

12. A method as recited in claim 11, in which the step of providing the swivel housing comprises the steps of:

providing a swivel housing member;  
securing a first housing cap to the swivel housing member; and  
securing a second housing cap to the swivel housing member.

13. A method as recited in claim 12, further comprising the steps of:  
forming first and second bearing surfaces on the swivel housing member;  
arranging the first bearing such that the first bearing is held against the  
first bearing surface by the first housing cap; and  
arranging the second bearing such that the second bearing is held against  
the second bearing surface by the second housing cap.

14. A method as recited in claim 11, further comprising the step of forming a swivel chamber between the swivel housing and the swivel member.

15. A method as recited in claim 11, in which the step of providing the swivel member comprises the step of forming an inner chamber in the swivel member that extends between the first and second swivel member connectors to allow fluid flow through the swivel member.

16. A method as recited in claim 11, further comprising the steps of:  
providing at least one adapter assembly; and  
arranging the at least one adapter assembly to transmit rotational movement of the rotational drive system to the swivel member.

17. A system for driving a helical pile, comprising:  
a rotational drive system adapted to drive the helical pile;

at least one clamp system;  
at least one accessory; and  
a swivel assembly comprising  
    a swivel member defining first and second swivel member  
        connector portions,  
    a swivel housing, and  
    first and second bearings operatively arranged between the swivel  
        member and the swivel housing; wherein  
the first swivel member connector portion is adapted to operatively  
    connect the swivel member to the drive system;  
the second swivel member connector portion is adapted to operatively  
    connect the swivel member to the at least one accessory;  
the swivel housing is adapted to engage the at least one clamp system  
    such that the clamp system may be operated to fix a position of the  
    swivel housing relative to the drive system; and  
the first and second bearings are configured to allow rotation of the swivel  
    member relative to the swivel housing.

18. A system as recited in claim 17, in which:  
a swivel chamber is defined by the swivel housing and the swivel member;  
    and  
the swivel member defines an inner chamber extending between the first  
    and second swivel member connectors to allow fluid flow through  
    the swivel member.

19. A system as recited in claim 17, further comprising at least one  
adapter assembly configured to transmit rotational movement of the rotational  
drive system to the swivel member.

20. A system as recited in claim 17, in which the accessory is selected from a group of accessories consisting of an auger, a drill, and a downhole hammer.

21. A mounting system for operatively connecting a helical pile driving system comprising a rotational drive system defining a drive connector and at least one clamp system to a helical pile defining a pile connector and to an accessory defining an accessory connector, the accessory mounting system comprising:

a swivel assembly defining a swivel assembly first connector and a swivel assembly second connector, the swivel assembly comprising:

a swivel housing,

a swivel member a middle portion, where the swivel member comprising is arranged at least partly within the swivel housing such that the middle portion and the swivel housing define a swivel chamber,

the swivel assembly first connector extends from an upper end of the middle portion, and the swivel assembly second connector extends from a lower end of the middle portion, and

the swivel assembly second connector extends from a lower end of the middle portion, and

first and second bearings operatively arranged between the swivel member and the swivel housing to support the swivel member for axial rotation relative to the swivel housing;

wherein the mounting system operates in a first mode in which the swivel assembly first connector engages the drive connector to connect the swivel member to the rotational drive system;

the swivel assembly second connector engages the accessory connector to connect the swivel member to the accessory;

the at least one clamp system engages the swivel housing such that the clamp system secures the swivel housing to the rotational drive system, and operation of the rotational drive system causes rotation of the accessory; and

a second mode in which the pile connector engages the drive connector to connect the helical pile to the rotational drive system, and operation of the rotational drive system causes rotation of the helical pile.

22. A mounting system as recited in claim 21, in which the swivel housing comprises:  
a swivel housing member;  
a first housing cap secured to the swivel housing member; and  
a second housing cap secured to the swivel housing member.
23. A mounting system as recited in claim 22, in which: the swivel housing member defines first and second bearing surfaces;  
the first bearing is held against the first bearing surface by the first housing cap; and  
the second bearing is held against the second bearing surface by the second housing cap.
24. A mounting system as recited in claim 21, in which the swivel member defines an inner chamber extending between the swivel assembly first and second connectors to channel fluid flow from the rotational drive system, through the swivel member, and into one of the helical pile and the accessory connected to the swivel assembly.
25. A mounting system as recited in claim 21, in which the swivel member defines an inner chamber extending between the swivel assembly first and second connectors to allow fluid flow through the swivel member.
26. A mounting system as recited in claim 21, further comprising an adapter assembly defining the swivel assembly first connector.
27. A mounting system as recited in claim 26, in which:  
the adapter member defines a first adapter connector; and  
the swivel member defines a second adapter connector;  
wherein the first adapter connector engages the second adapter connector to connect the adapter assembly to the swivel member.
28. A mounting system as recited in claim 21, in which:  
the mounting system comprises a plurality of different rotational drive systems; and  
the swivel assembly further comprises a plurality of adapter assemblies, where each adapter assembly is configured to transmit to the swivel member rotational movement of one of the plurality of different rotational drive systems.

29. A mounting system as recited in claim 21, in which the accessory is selected from a group of accessories consisting of an auger, a drill, and a downhole hammer.

30. A method of operatively connecting a helical pile driving system comprising a rotational drive system and at least one clamp system to a helical pile and to an accessory, the method comprising the steps of:

providing a swivel member defining first and second swivel member connector portions;  
providing a swivel housing;

providing first and second bearings;

forming a swivel assembly by arranging the first and second bearings between the swivel member and the swivel housing to allow rotation of the swivel member relative to the swivel housing;

operating in a first mode by operatively connecting the swivel member to the drive system using the first swivel member connector portion, operatively connecting the swivel member to the accessory using the second swivel member connector portion, operating the clamp system to secure the swivel housing to the drive system by engaging the swivel housing with the at least one clamp system, and operating the rotational drive system to cause rotation of the accessory; and

operating in a second mode by operatively connecting the helical pile to the rotational drive system, and operating the rotational drive system to cause rotation of the helical pile.

31. A method as recited in claim 30, in which the step of forming the swivel assembly further comprises the steps of:

providing an adapter assembly defining an adapter drive connector and an adapter swivel connector;

engaging the adapter swivel connector to the first swivel member connector portion to connect the adapter assembly to the swivel member; and

engaging the adapter drive connection to the rotational drive system to operatively connect the adapter assembly to the rotational drive system.

32. A method as recited in claim 31, further comprising the steps of:

providing a plurality of different rotational drive systems;

providing a plurality of different adapter assemblies;

selecting one of the plurality of rotational drive systems;

selecting one of the plurality of different adapter assemblies based on the selected rotational drive system;

connecting the selected adapter assembly to the swivel member; and

connecting the selected adapter assembly to the selected rotational drive system.

33. A method as recited in claim 30, in which the step of forming the swivel assembly further comprises the step of forming a swivel chamber between the swivel housing and the swivel member.

34. A method as recited in claim 30, in which the step of providing the swivel member comprises the step of forming an inner chamber in the swivel member that extends between the first and second swivel member connectors to allow fluid flow through the swivel member.

35. A method as recited in claim 30, in which the accessory is one of a group of accessories consisting of an auger, a drill, and a downhole hammer, the method further comprising the step of identifying a selected one of the accessories in the group of accessories.

36. A drive system for driving a helical pile, comprising:

a rotational drive system adapted to drive the helical pile;

at least one clamp system;

at least one accessory; and a swivel assembly comprising a swivel member defining first and second swivel member connector portions, a swivel housing, first and second bearings operatively arranged between the swivel member and the swivel housing to allow rotation of the swivel member relative to the swivel housing, and at least one adapter member defining first and second adapter member connector portions;

wherein the first swivel member connector portion is adapted to engage the first adapter member connector portion to operatively connect the swivel member to the adapter member;

the second adapter member connector portion is adapted to engage the rotational drive system to operatively connect the at least one adapter member to the rotational drive system;

the second swivel member connector portion is adapted to engage the at least one accessory to operatively connect the swivel member to the at least one accessory;

wherein the first adapter member connector portion engages the first swivel member connector portion to detachably attach the at least one adapter member to the swivel member;



the second adapter member connector portion engages the rotational drive system to detachably attach the swivel member to the rotational drive system;

the second swivel member connector portion engages the at least one accessory to attach the swivel member to the at least one accessory;

the at least one clamp system engages the swivel housing such that the clamp system secures the swivel housing relative to the rotational drive system, and operation of the rotational drive system causes rotation of the accessory.

37. A drive system as recited in claim 36, in which the accessory is selected from a group of accessories consisting of an auger, a drill, and a downhole hammer.

38. A drive system as recited in claim 36, further comprising:

a plurality of different rotational drive systems; and

the swivel assembly further comprises a plurality of adapter assemblies, where each adapter assembly is configured to transmit rotational movement of one of the plurality of different rotational drive systems.

FIG. 1A

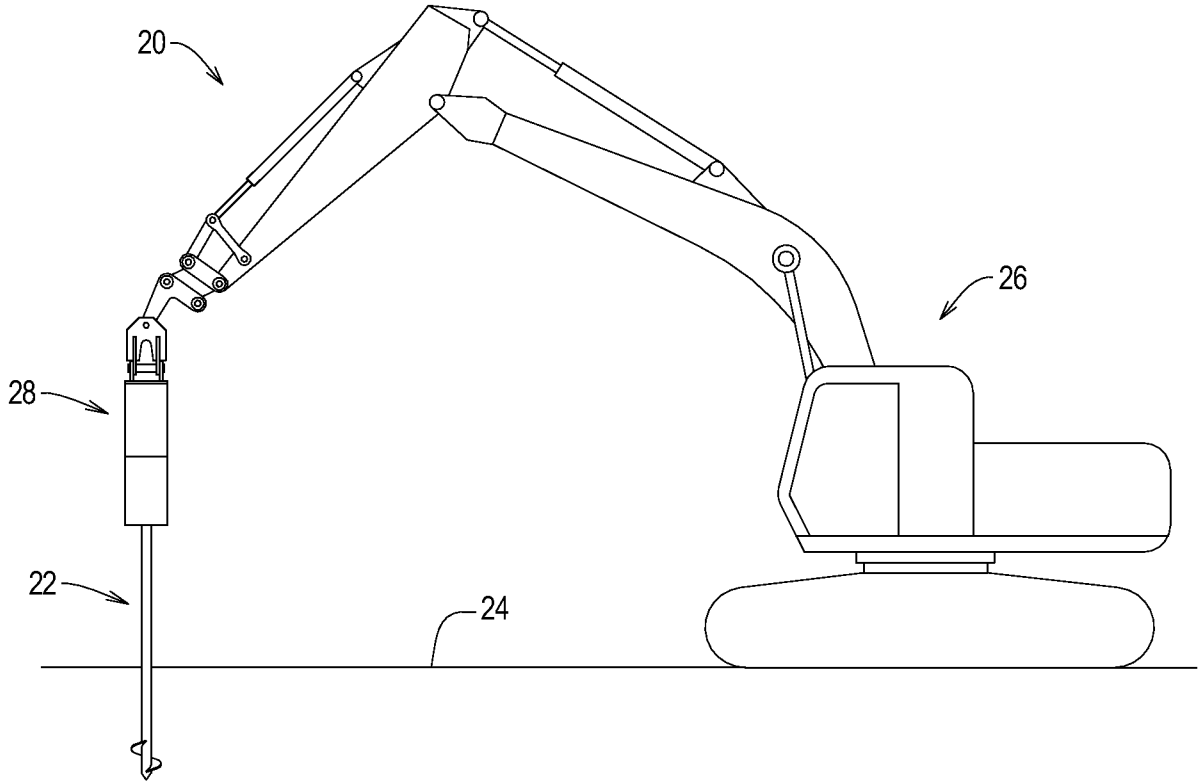

FIG. 1B

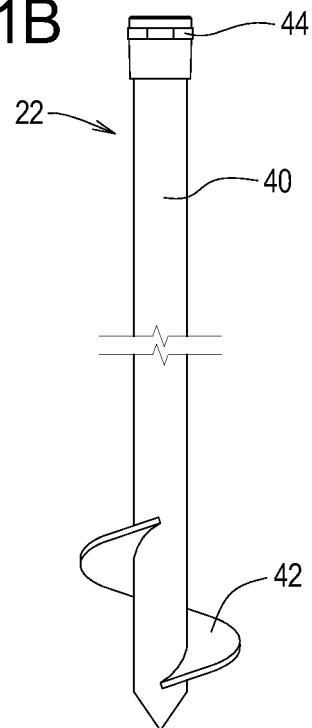

FIG. 2A

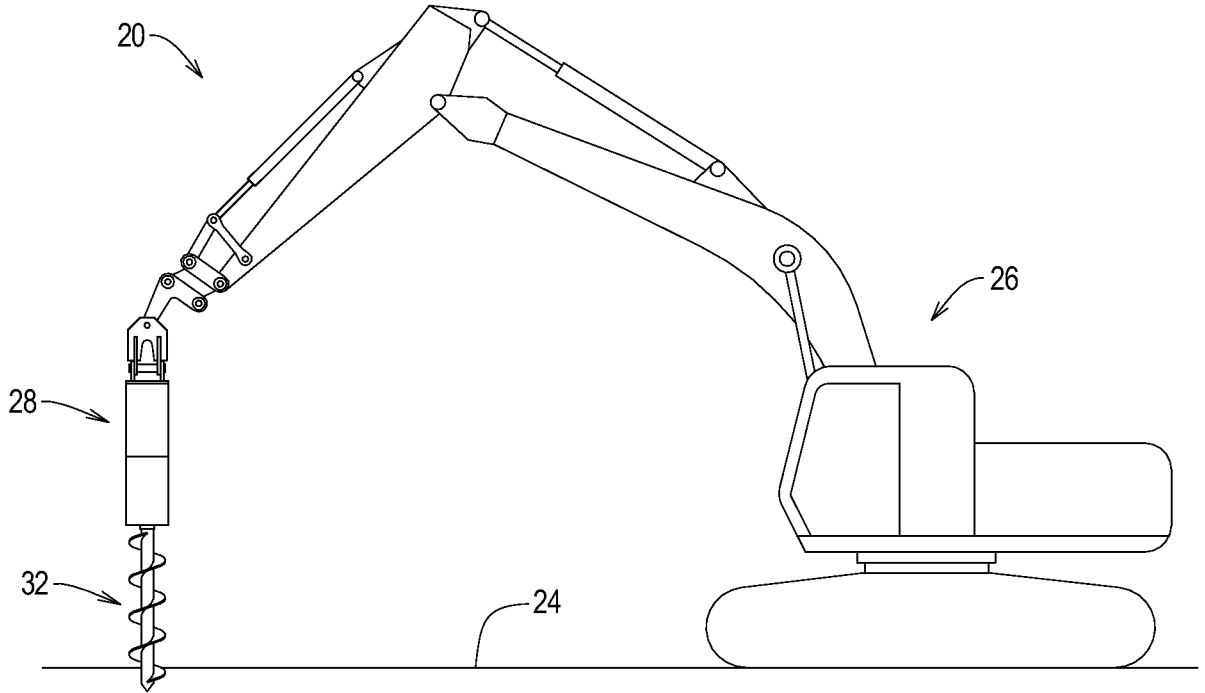
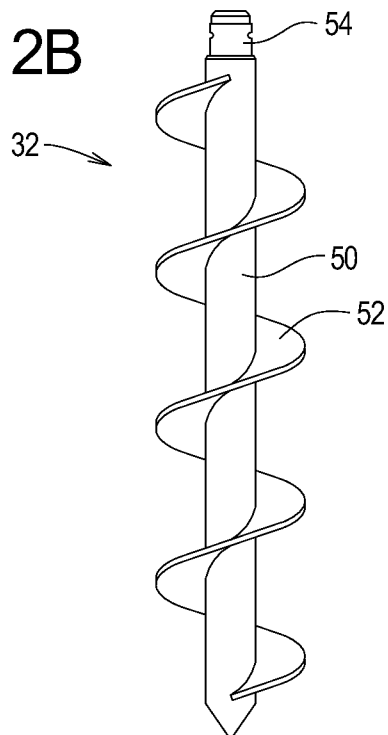
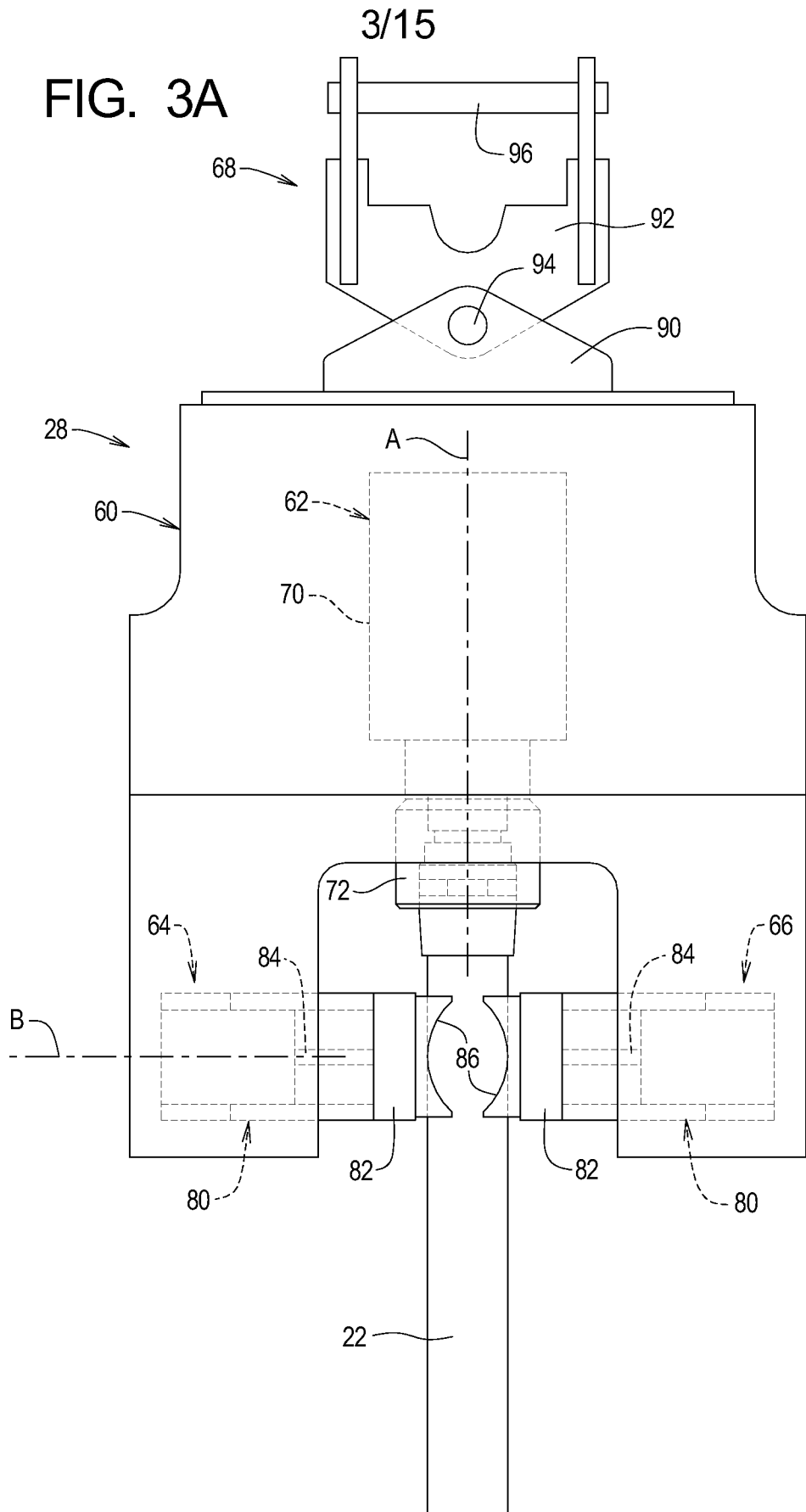

FIG. 2B





4/15

FIG. 3B

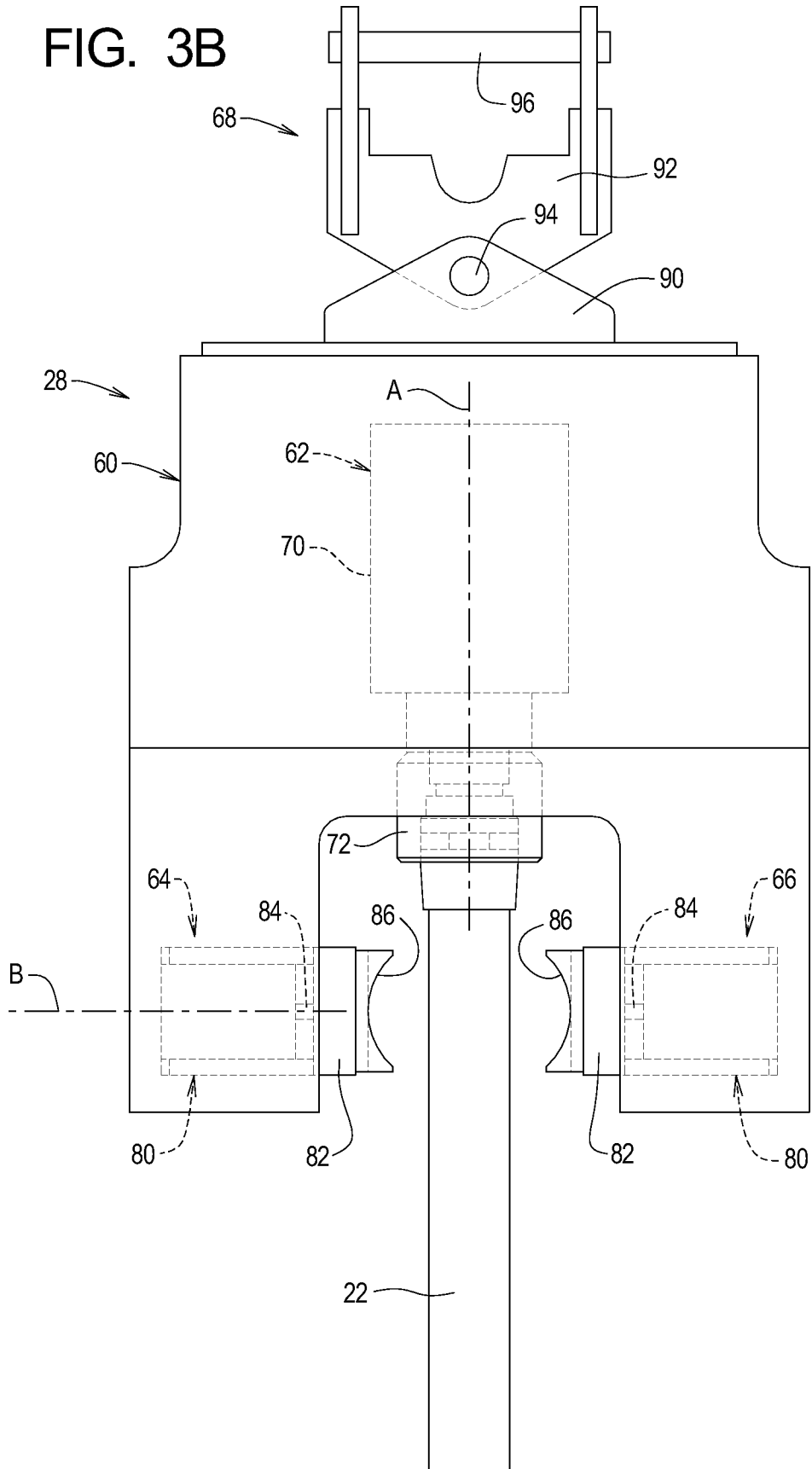

5/15

FIG. 4A

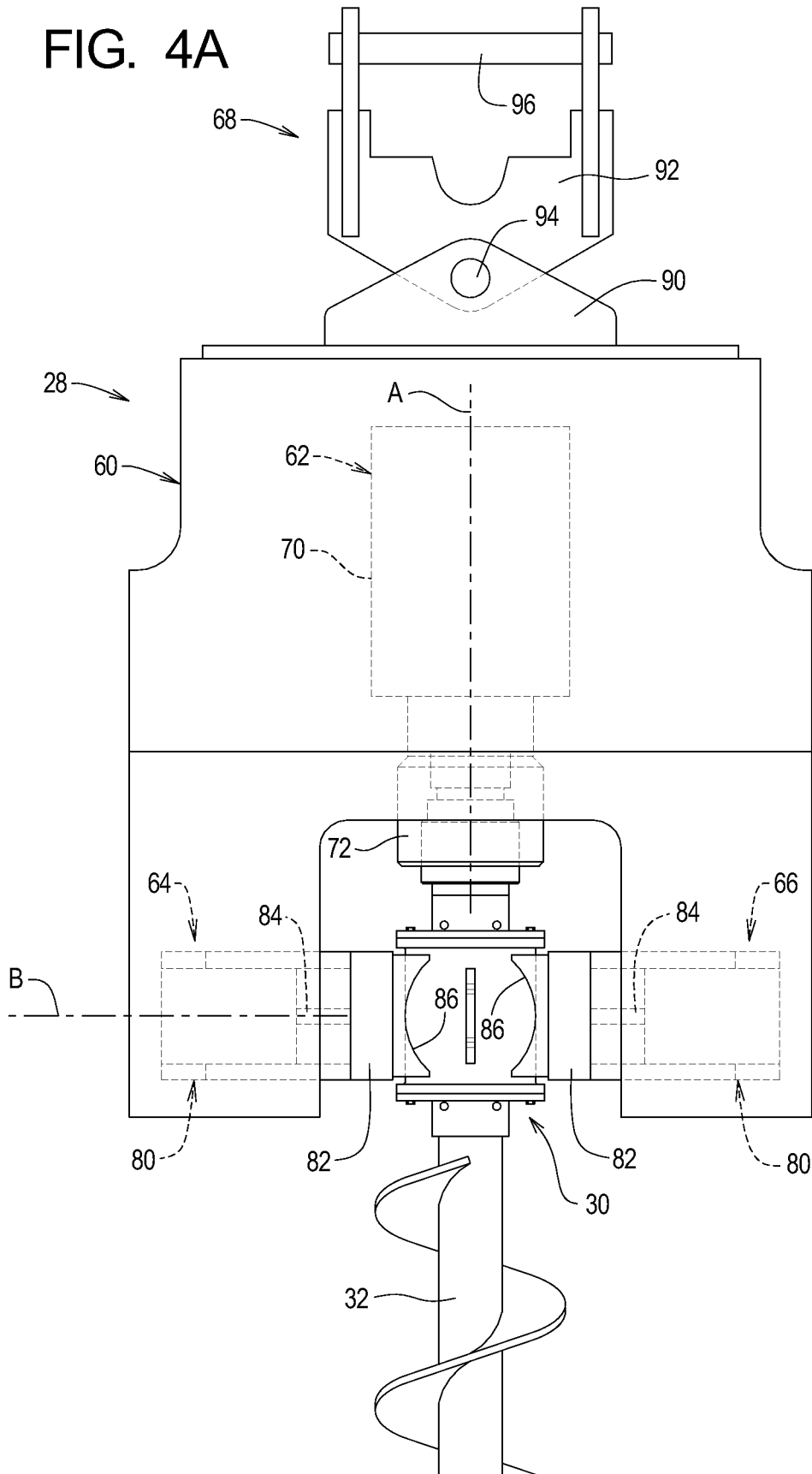

6/15

FIG. 4B

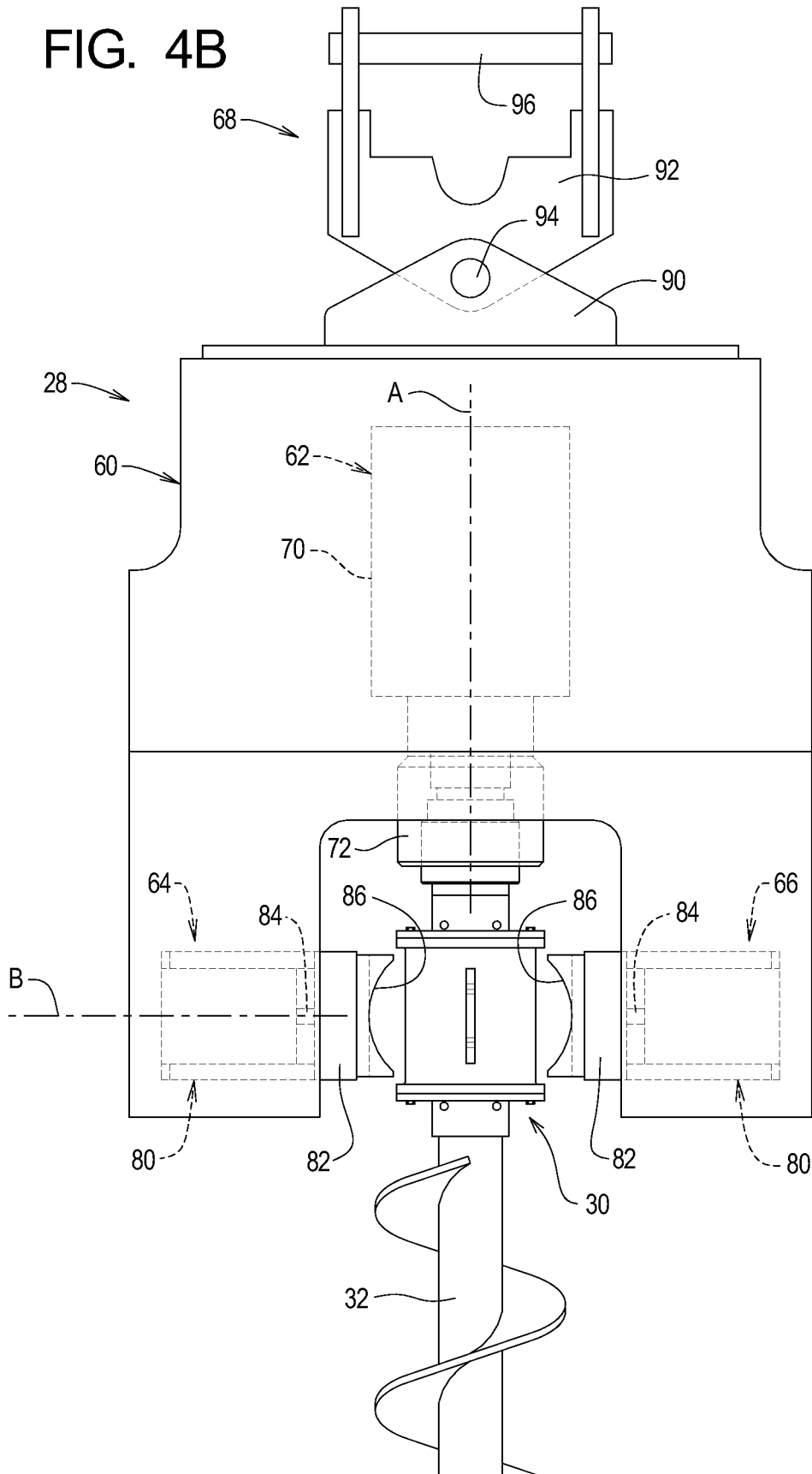

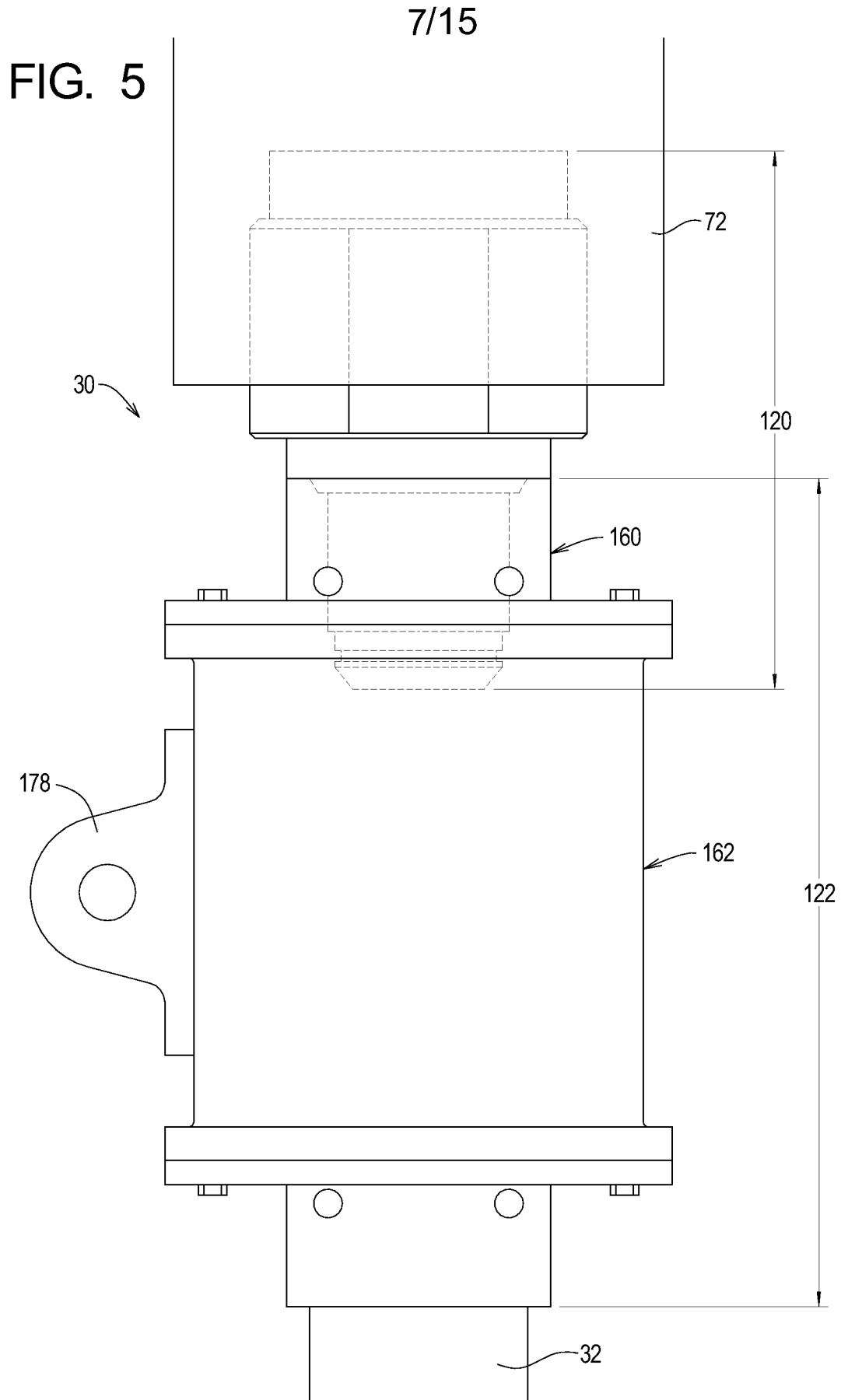



8/15

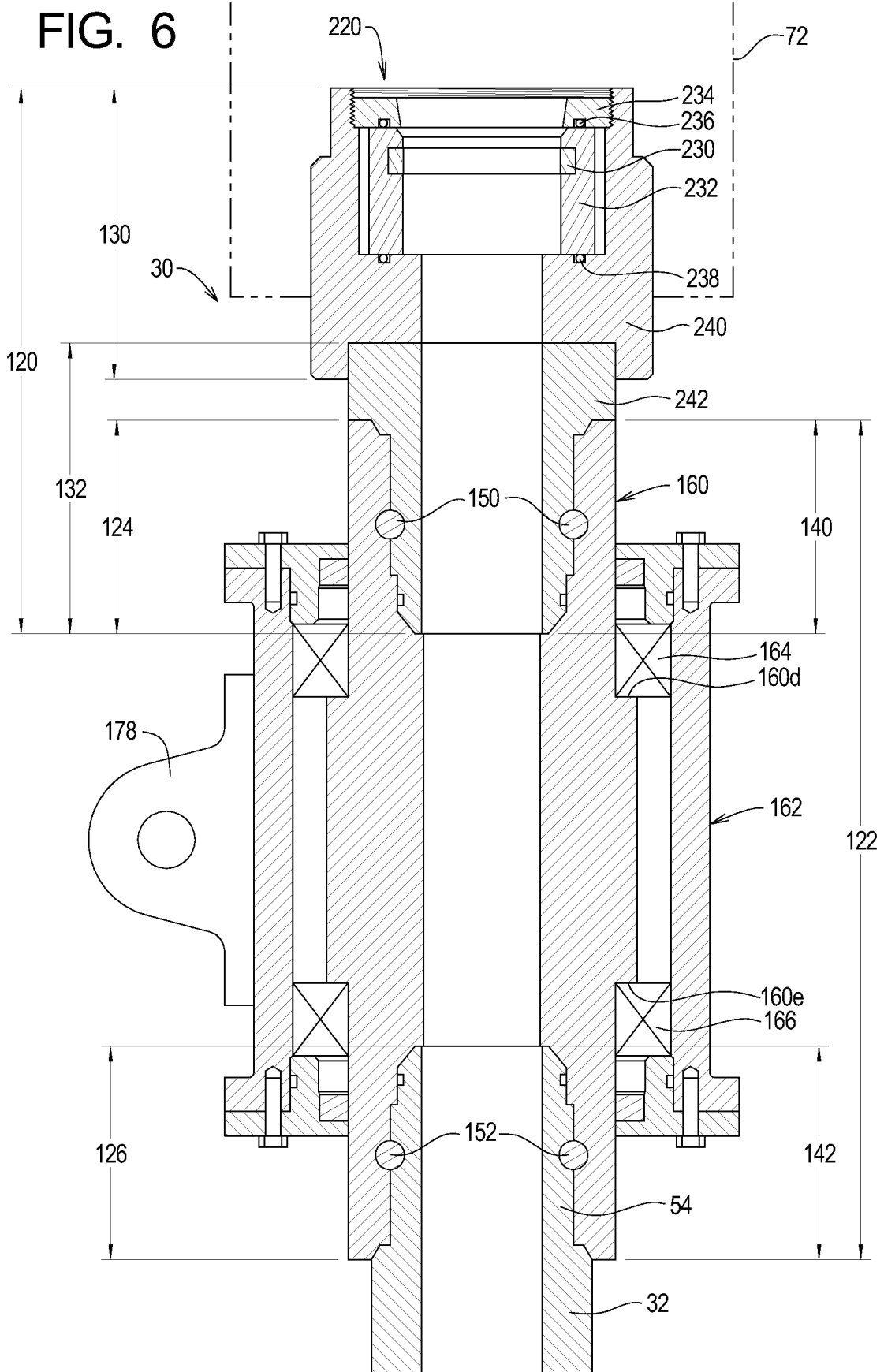
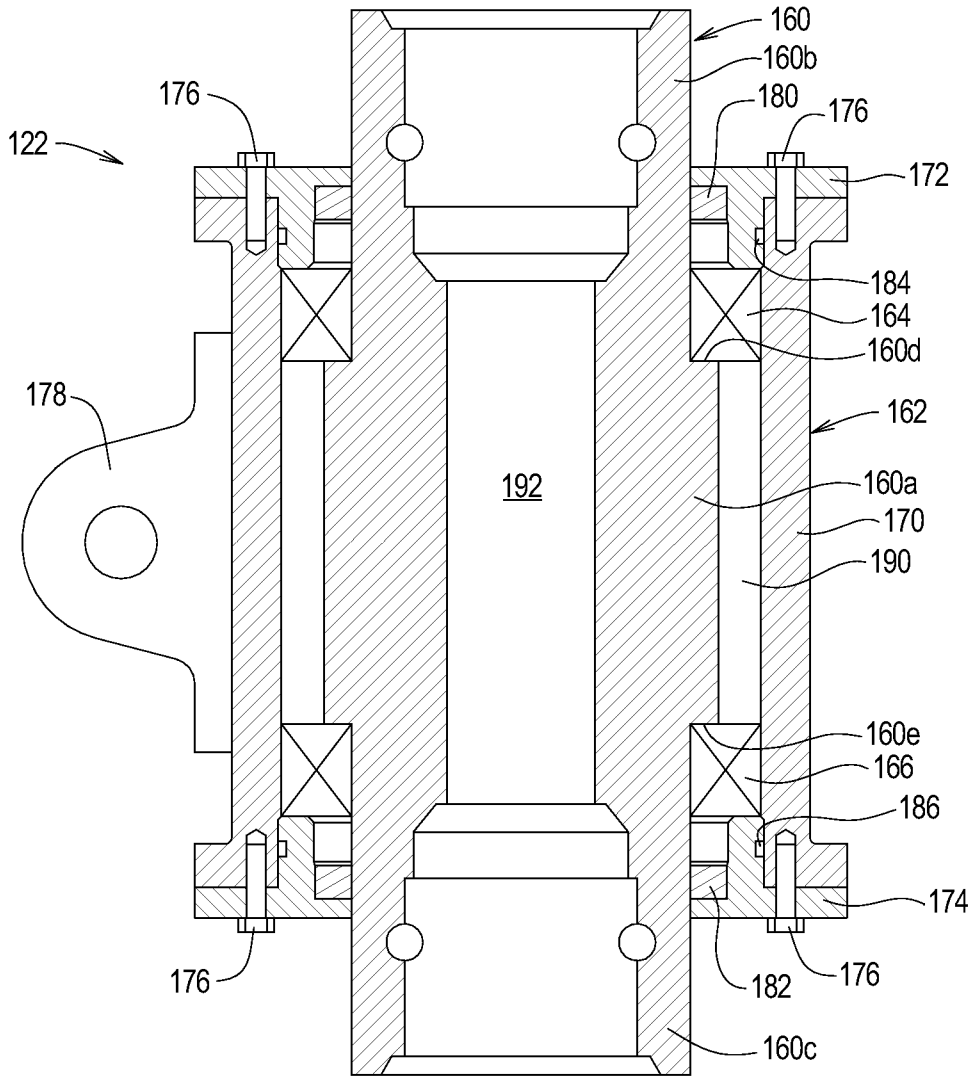

FIG. 7



10/15

FIG. 8

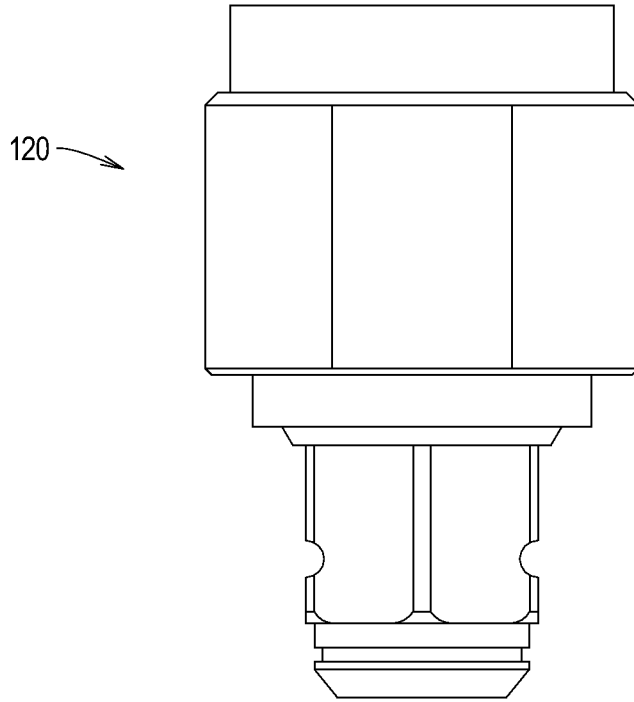
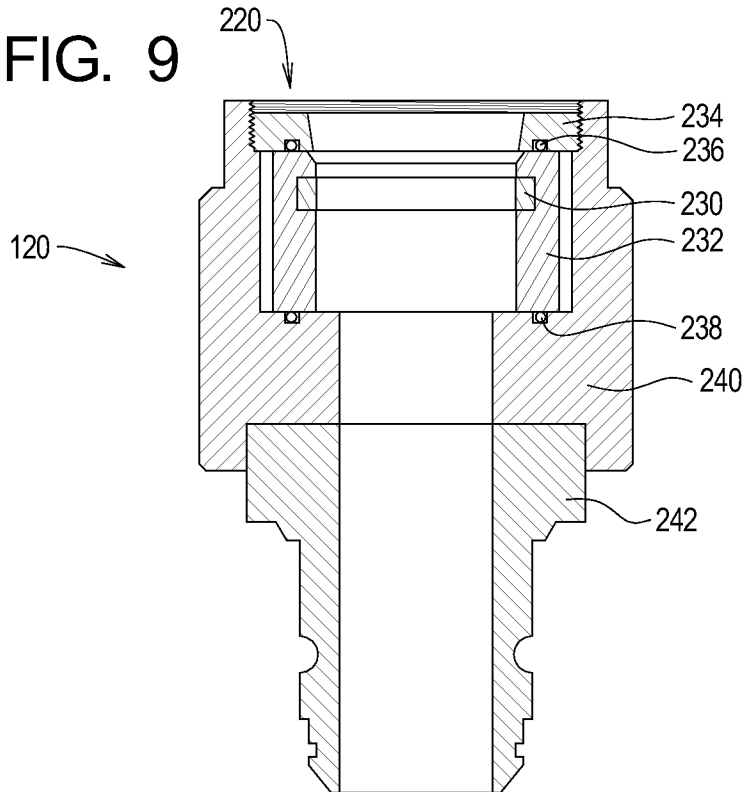

FIG. 9



11/15

FIG. 10

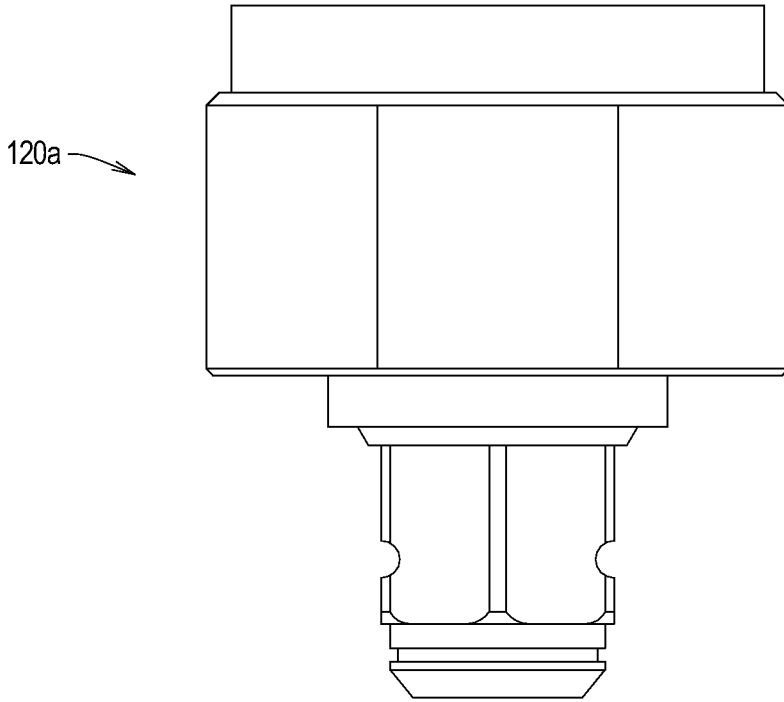
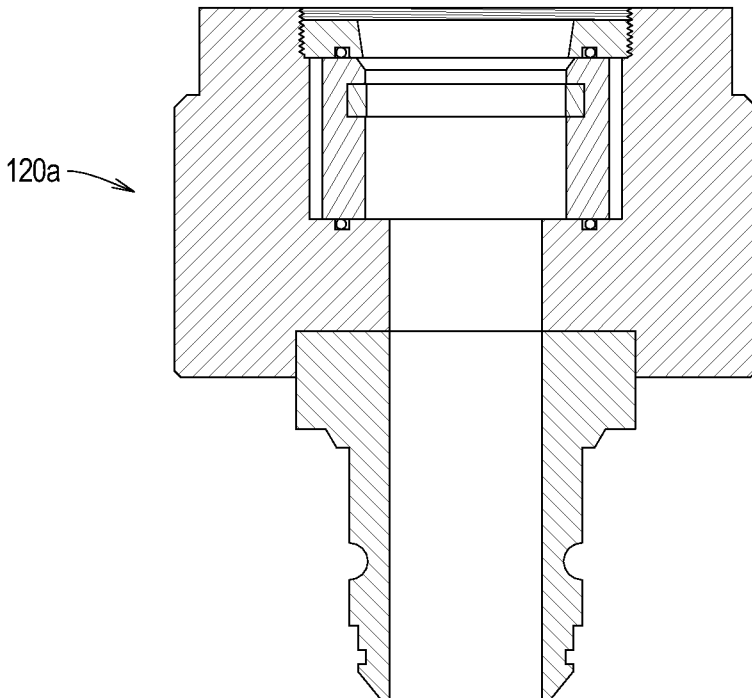

FIG. 11



12/15

FIG. 12

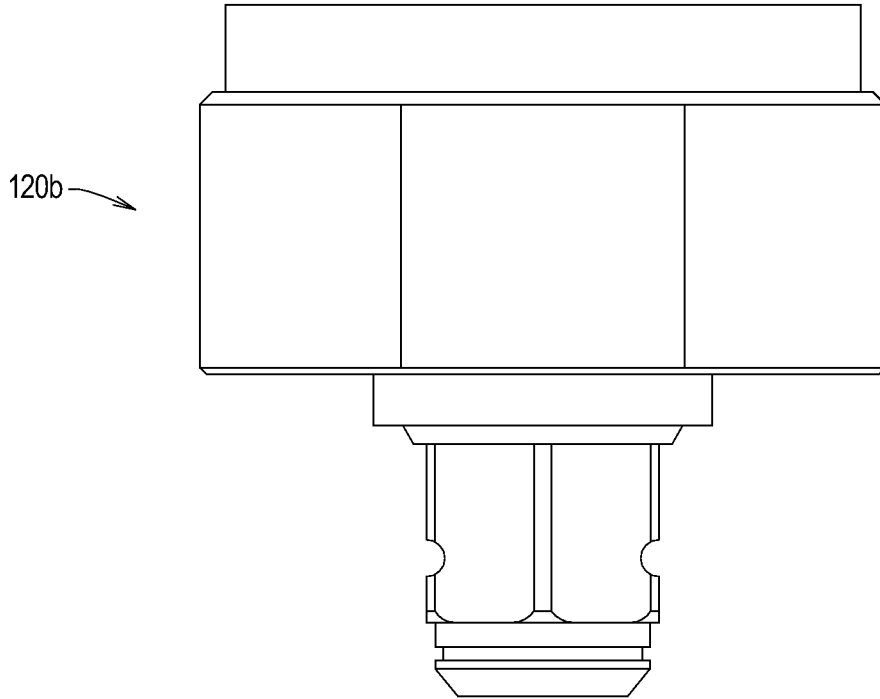
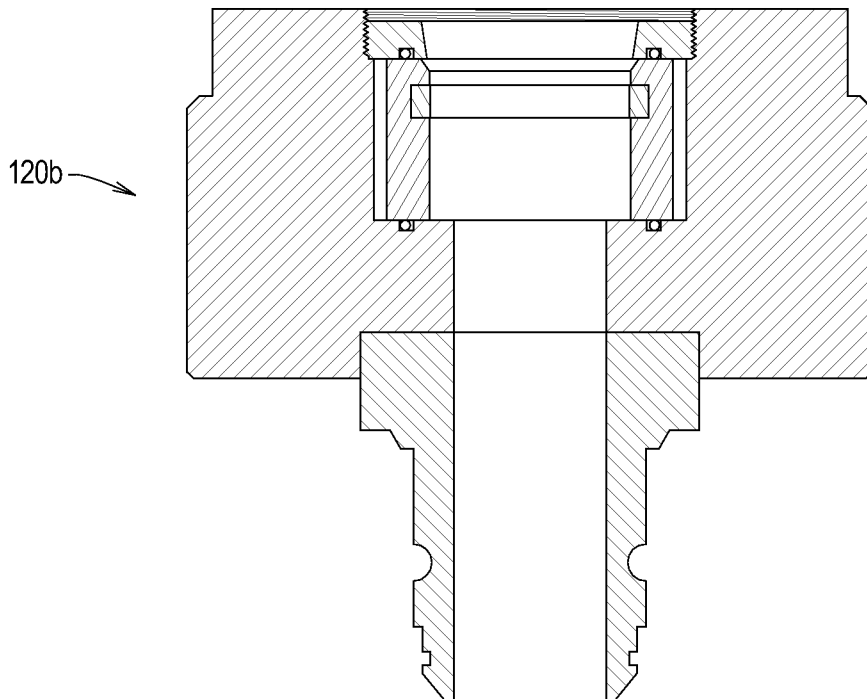

FIG. 13



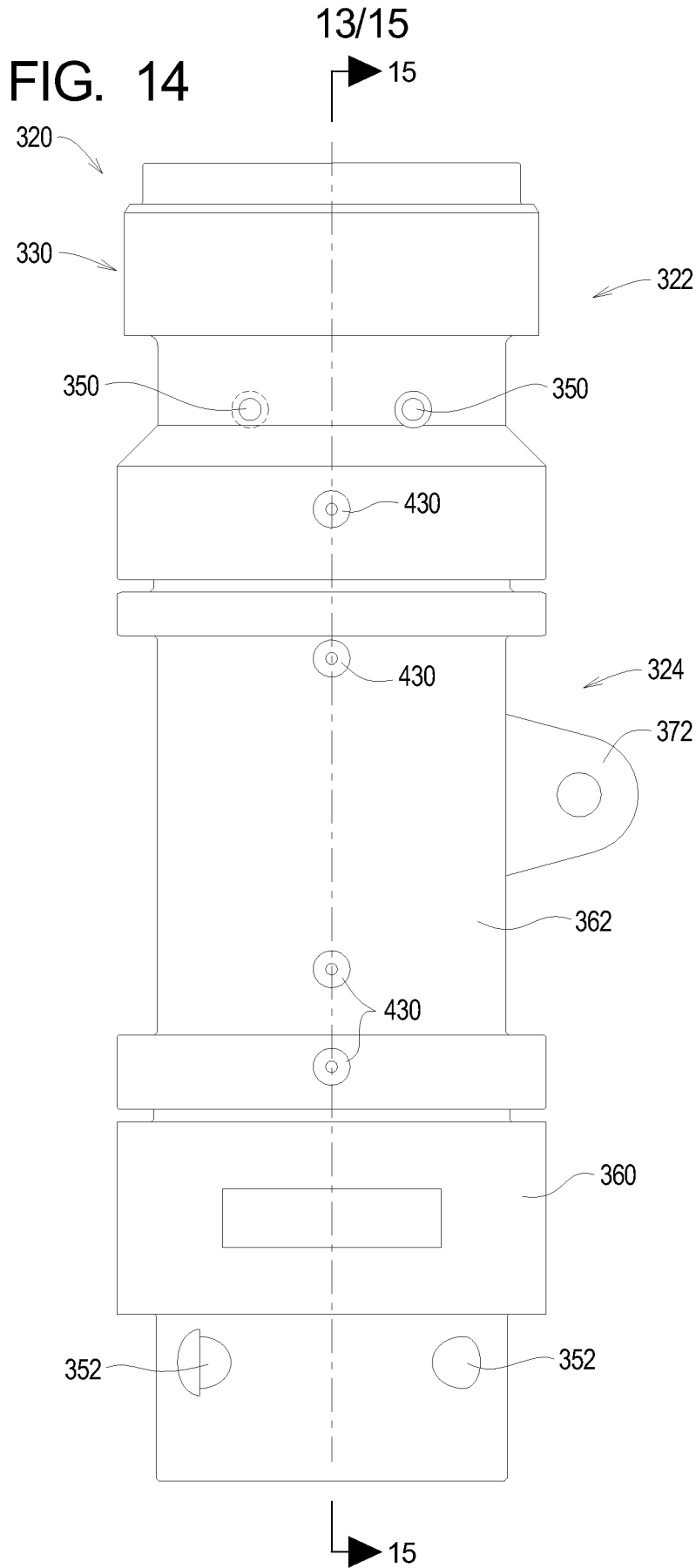

FIG. 15

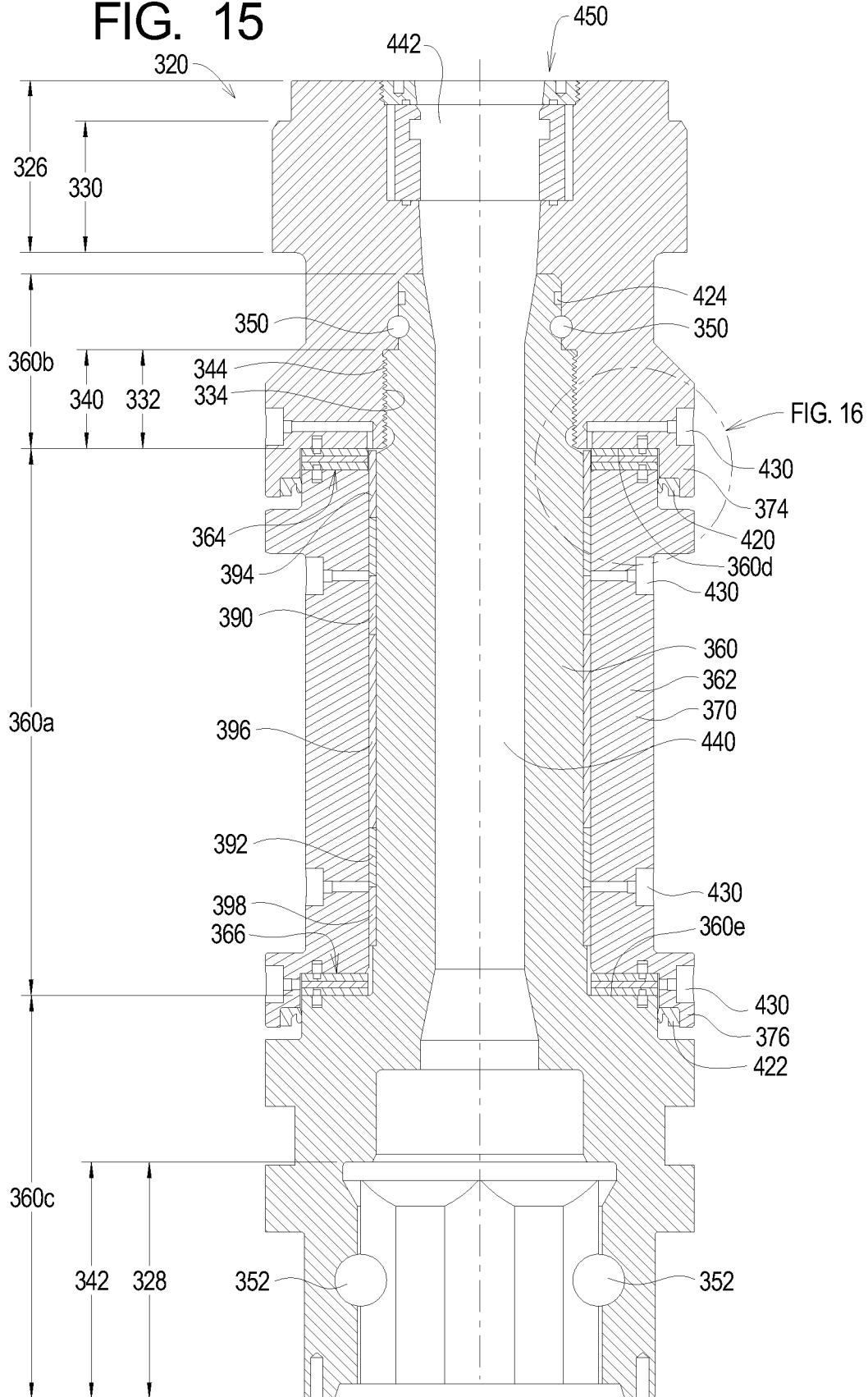

FIG. 16

